

Electric Motors

IE2 Motors

hoyermotors.com

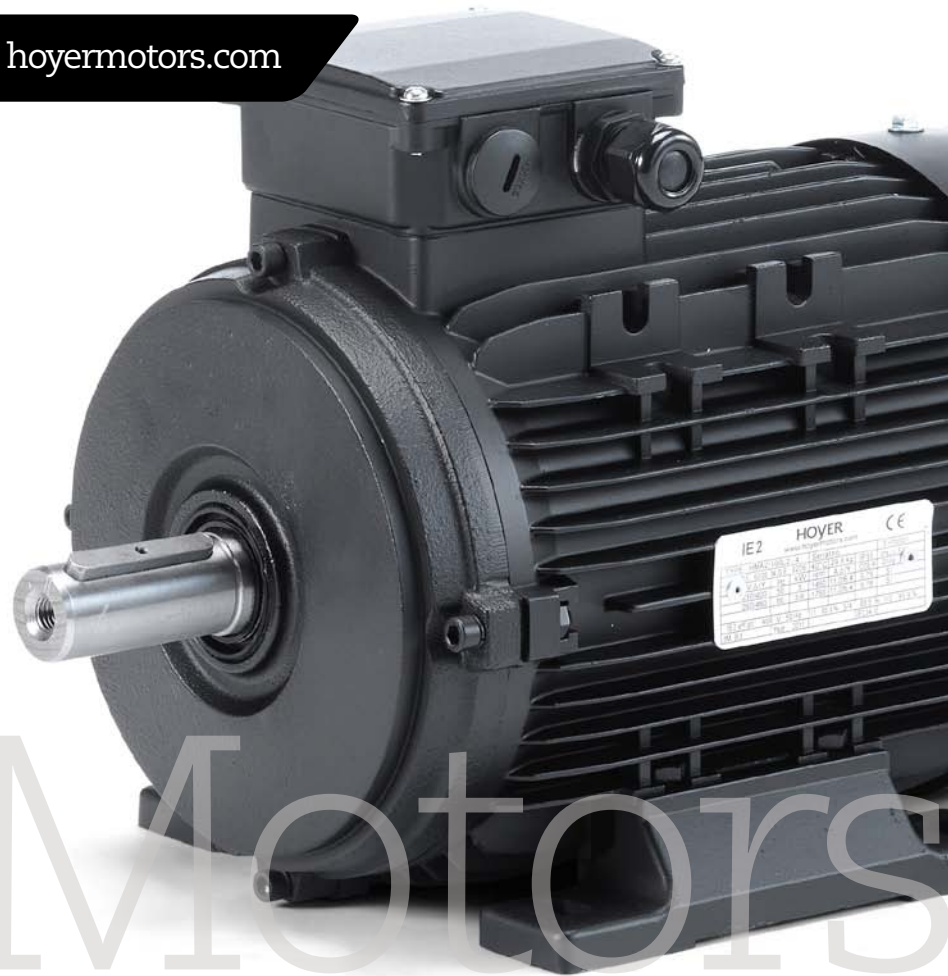

IE2 Motors

HOYER ▶
MOTORS



HOYER

EXCEEDING EXPECTATIONS

Sometimes it's not easy to see what makes up a company. But you may be surprised. Even positively so. This is definitely the case with Svend Hoyer A/S, the company behind the two business units Hoyer Motors and Hoyer Transmissions. Svend Hoyer A/S is an international company headquartered in Denmark with subsidiaries in Norway, Sweden, Germany and China. A professional enterprise focusing on service and support and where perfectionism and reliability are second to none.

Svend Hoyer A/S always meets its agreements based on the motto: 'A promise is a promise'. This is the starting point for supplying solutions that match our customers' expectations. We are honest and direct in our approach – even in case of complaints or criticism. Svend Hoyer A/S is a company you can rely on. And you can count on our deliveries and our solutions – both in the short and long term. This is what we mean by Exceeding Expectations.

General information about Hoyer IE2 electric motors

Hoyer IE2 electric motors are manufactured according to international standards under IEC and are fulfilling the requirement of the EC Directive 2005/32 (IE2-directive).

Hoyer motors are installed in many different industrial fields all over the world, and with a proven quality, high reliability and performance, Hoyer IE2 is a known brand in the market.

Technical information

Totally enclosed squirrel cage, TEFV, three phase motors type HMA2 (aluminum) in size 56 to 132 (size 160 and 180 on request) and type HMC2 (cast iron) in size 160 to 400 (below size 160 and bigger than size 400 on request).

Rotor is casted with 100% pure aluminum and shaft is made of high quality C45 steel.

HMC2 motors are provided with SKF bearings. HMA2 motors are supplied with C&U bearings. All sizes have fixed bearing in drive-end as standard.

Stator winding is made with double coated copper wire and phase to phase insulation. The insulation system is Class F, maximum 105K temperature rise at 40°C ambient temperature.

Motors below 200kW are designed for Class B temperature rise.

Class H insulation system can be delivered on request.

All motors are manufactured according to IEC 60034, IEC60072, EN50347 and tested according to IEC60034-2-1.

Rotor is dynamically balanced with half key to fulfill vibration level IEC60034-14 grade A.
Sound level within limits of IEC60034-9.

Hoyer IE2 motors $\leq 3\text{kW}$ are manufactured for 230/400V 50Hz and $> 3\text{kW}$ for 400/690V 50Hz. Other voltages can be supplied on request.

All Hoyer IE2 motors are with PTC terminal protection. Motors can be modified with bimetal detector, heating elements for stand still protection and PT100 for both winding and bearings on request.

Protection is IP55 with shaft sealing as standard. Higher protection class on request.

Motor size ≥ 112 are supplied with eyebolts for lifting.

Hoyer IE2 motors are painted black RAL 9005 with low gloss for use in normal industrial environments.

Application info

Hoyer IE2 electric motors are used within a wide variety of applications. Some of the typical applications are listed below:

- Fans (air handling units, refrigeration plants, oil coolers)
- Hydraulic power packs
- Pumps (for water, fuel, oil)
- Shredders (granulation, crushing)
- Gears (gear reducers, gearmotors)



Motor type	Power kW	Speed rpm	Current at 400V		Efficiency (%)			Pf. cosφ	Torque			IM J(kgm ²)	Weight kg
			I _N (A)	I _S /I _N	1/4 load	1/2 load	3/4 load		TN	TS/TN	T _{max} /TN		

Aluminium motors

HMA2 801-2	0,75	2850	1,7	7,5	81,4	81,2	78,3	0,81	2,5	2,5	3,2	0,0011	9,0
HMA2 802-2	1,1	2880	2,3	7,7	80,9	79,9	76,1	0,82	3,6	3,2	3,3	0,0013	11
HMA2 90S-2	1,5	2850	3,1	8,4	83,5	83,0	80,2	0,85	4,9	2,9	3,1	0,0018	15
HMA2 90L-2	2,2	2850	4,4	8,5	85,7	85,8	83,9	0,85	7,2	2,9	3,2	0,0022	17
HMA2 100L-2	3,0	2890	5,8	8,7	85,7	85,5	83,4	0,87	9,9	3,1	3,5	0,0043	23
HMA2 112M1-2	4,0	2900	7,5	8,4	87,0	87,1	85,4	0,90	13	3,2	3,4	0,0065	32
HMA2 132S1-2	5,5	2880	10,5	8,4	87,0	86,3	83,6	0,89	18	2,4	3,5	0,015	45
HMA2 132S2-2	7,5	2900	13,5	8,4	88,1	87,6	85,3	0,90	25	2,4	3,5	0,016	51

Cast iron motors

HMC2 160M1-2	11	2930	20	7,9	89,4	89,3	87,5	0,89	36	2,2	2,3	0,040	114
HMC2 160M2-2	15	2930	27	8,0	90,3	90,3	89,2	0,89	49	2,2	2,3	0,047	122
HMC2 160L-2	18,5	2930	33	8,1	90,9	91,3	90,4	0,89	60	2,2	2,3	0,058	144
HMC2 180M-2	22	2940	39	8,2	91,3	91,1	89,7	0,89	71	2,2	2,3	0,079	175
HMC2 200L1-2	30	2950	53	7,5	92,0	92,2	90,7	0,89	97	2,2	2,3	0,130	251
HMC2 200L2-2	37	2950	65	7,5	92,5	92,7	90,1	0,89	119	2,2	2,3	0,146	266
HMC2 225M-2	45	2960	78	7,6	92,9	92,4	90,5	0,89	145	2,2	2,3	0,246	330
HMC2 250M-2	55	2970	96	7,6	93,2	92,7	90,8	0,89	177	2,2	2,3	0,328	403
HMC2 280S-2	75	2970	129	6,9	93,8	93,6	92,5	0,89	240	2,0	2,3	0,627	565
HMC2 280M-2	90	2970	155	7,0	94,1	93,9	92,8	0,89	289	2,0	2,3	0,709	620
HMC2 315S-2	110	2980	187	7,1	94,3	94,0	92,8	0,90	352	2,0	2,2	1,124	965
HMC2 315M-2	132	2980	223	7,1	94,6	94,0	92,8	0,90	425	2,0	2,2	1,91	1080
HMC2 315L1-2	160	2980	267	7,1	94,8	94,1	92,9	0,91	513	2,0	2,2	2,18	1170
HMC2 315L2-2	200	2980	334	7,1	95,0	94,1	92,9	0,91	640	2,0	2,2	2,53	1215
HMC2 355M-2	250	2980	417	7,1	95,0	94,9	94,5	0,91	800	2,0	2,2	4,52	1725
HMC2 355L1-2	315	2980	526	7,1	95,0	94,9	94,5	0,91	1010	2,0	2,2	5,35	2070
HMC2 355L2-2	355	2980	590	7,1	95,3	95,3	95,0	0,92	1135	1,8	2,2	5,10	2300
HMC2 400M2-2	400	2980	675	7,1	95,5	95,5	95,2	0,92	1280	1,8	2,2	5,57	2950
HMC2 400M3-2	450	2980	755	7,1	95,5	95,5	95,2	0,92	1430	1,8	2,2	7,05	3200
HMC2 400L1-2	500	2985	830	7,0	95,8	95,8	95,5	0,92	1595	1,8	2,2	7,10	3250
HMC2 400L2-2	560	2985	930	7,0	95,8	95,8	95,5	0,92	1780	1,8	2,2	7,15	3300

Data at 400V 50Hz

At 230V 50Hz the current is $\sqrt{3}$ x current at 400V and at 690V the current is current at 400V / $\sqrt{3}$. All other data are identical.

Motor type	Power kW	Speed rpm	Current at 400V		Efficiency (%)			Pf. cosφ	Torque			IM J(kgm ²)	Weight kg
			I _N (A)	I _s /I _N	1/1 load	3/4 load	1/2 load		TN	TS/TN	T _{max} /TN		

Aluminium motors

HMA2 802-4	0,75	1420	1,8	5,9	80,8	81,1	78,8	0,78	5,0	2,5	2,6	0,0017	13
HMA2 90S-4	1,1	1420	2,6	5,5	81,5	81,2	79,6	0,73	7,4	2,5	3,2	0,0023	17
HMA2 90L-4	1,5	1450	3,4	6,6	84,4	83,7	80,6	0,71	9,9	2,7	3,4	0,0031	18
HMA2 100L1-4	2,2	1440	4,6	7,3	85,2	84,8	82,3	0,78	14,5	2,5	3,4	0,0078	26
HMA2 100L2-4	3,0	1440	6,1	7,3	86,3	85,9	83,6	0,77	20	2,6	3,4	0,0087	28
HMA2 112M2-4	4,0	1450	7,9	7,1	86,7	86,9	85,2	0,84	26	2,2	2,9	0,019	37
HMA2 132S-4	5,5	1450	11	7,5	88,4	88,1	86,2	0,80	36	2,3	3,3	0,033	51
HMA2 132M2-4	7,5	1460	15	7,3	88,9	89,1	87,9	0,82	49	2,2	3,2	0,41	62

Cast iron motors

HMC2 160M-4	11	1460	21	7,5	89,8	89,7	89,2	0,85	72	2,2	2,3	0,078	122
HMC2 160L-4	15	1460	28	7,5	90,6	90,5	87,9	0,86	98	2,2	2,3	0,096	138
HMC2 180M-4	18,5	1470	34	7,7	91,2	91,7	91,0	0,86	120	2,2	2,3	0,146	174
HMC2 180L-4	22	1470	40	7,8	91,6	91,9	91,3	0,86	143	2,2	2,3	0,166	195
HMC2 200L-4	30	1470	54	7,2	92,3	92,8	91,3	0,86	194	2,2	2,3	0,275	261
HMC2 225S-4	37	1475	67	7,3	92,7	92,8	90,9	0,86	238	2,2	2,3	0,426	344
HMC2 225M-4	45	1475	81	7,4	93,1	93,1	91,3	0,86	290	2,2	2,3	0,492	363
HMC2 250M-4	55	1480	99	7,4	93,5	93,8	91,5	0,86	354	2,2	2,3	0,693	422
HMC2 280S-4	75	1485	130	6,7	94,0	94,2	92,4	0,88	483	2,2	2,3	1,18	568
HMC2 280M-4	90	1485	156	6,9	94,2	94,5	92,7	0,88	580	2,2	2,3	1,53	668
HMC2 315S-4	110	1485	191	6,9	94,5	94,7	94,7	0,88	705	2,2	2,3	3,27	975
HMC2 315M-4	132	1485	228	6,9	94,7	94,9	94,3	0,88	850	2,2	2,3	3,80	1155
HMC2 315L1-4	160	1485	273	6,9	94,9	95,2	94,7	0,89	1030	2,2	2,3	4,34	1215
HMC2 315L2-4	200	1485	341	6,9	95,1	95,3	94,8	0,89	1285	2,2	2,3	5,37	1270
HMC2 355M-4	250	1490	421	6,9	95,1	95,5	94,8	0,90	1610	2,2	2,4	8,51	1780
HMC2 355L-4	315	1490	531	7,0	95,1	95,5	94,8	0,90	2025	2,2	2,4	10,8	1940
HMC2 355LB-4	355	1485	600	7,5	95,3	95,5	95,2	0,92	2285	2,2	2,4	12,4	2500
HMC2 400M1-4	400	1490	690	6,9	95,5	95,6	95,4	0,89	2565	1,4	3,0	14,9	3000
HMC2 400M2-4	450	1490	775	6,9	95,5	95,6	95,5	0,89	2885	1,4	3,0	15,2	3100
HMC2 400L1-4	500	1490	850	7,0	95,6	95,7	95,6	0,89	3200	1,3	3,0	18,5	3200
HMC2 400L2-4	560	1490	945	7,0	96,0	96,0	95,9	0,89	3590	1,4	3,0	19,4	3400
HMC2 400L3-4	630	1490	1110	7,1	96,0	96,1	96,0	0,89	4040	1,5	3,1	21,1	3500

Data at 400V 50Hz

At 230V 50Hz the current is $\sqrt{3}$ x current at 400V and at 690V the current is current at 400V / $\sqrt{3}$. All other data are identical.

Motor type	Power kW	Speed rpm	Current at 400V		Efficiency (%)			Pf. cosφ	Torque			IM J(kgm ²)	Weight kg
			I _N (A)	I _s /I _N	1/1 load	3/4 load	1/2 load		TN	TS/TN	T _{max} /TN		

Aluminium motors

HMA2 90S-6	0,75	960	1,9	4,5	75,9	74,4	69,6	0,65	7,5	2,1	2,7	0,0032	17,5
HMA2 90L-6	1,1	950	2,7	5,5	80,9	80,8	78,2	0,71	11	2,2	2,9	0,0041	21
HMA2 100L-6	1,5	960	3,6	5,5	80,1	80,1	77,3	0,68	15	2,3	2,6	0,0085	26
HMA2 112M1-6	2,2	960	5,2	5,9	83,6	83,8	81,7	0,71	22	2,3	2,8	0,013	35
HMA2 132S-6	3,0	960	6,9	6,9	85,5	85,4	83,2	0,74	29	2,1	2,8	0,037	46
HMA2 132M1-6	4,0	960	9,1	7,3	85,8	85,3	82,5	0,71	39	2,5	2,9	0,049	61
HMA2 132M2-6	5,5	960	12,5	7,4	87,4	87,2	85,2	0,73	54	2,5	2,9	0,059	66

Cast iron motors

HMC2 160M-6	7,5	970	16	6,7	87,2	87,1	84,3	0,78	74	2,1	2,3	0,093	115
HMC2 160L-6	11	970	22	6,9	88,7	88,6	85,0	0,79	108	2,1	2,2	0,122	137
HMC2 180L-6	15	970	30	7,2	89,7	89,3	86,7	0,81	146	2,0	2,2	0,217	182
HMC2 200L1-6	18,5	980	36	7,2	90,4	90,5	88,2	0,81	180	2,1	2,2	0,331	247
HMC2 200L2-6	22	980	42	7,3	90,9	90,9	88,5	0,82	214	2,1	2,2	0,378	261
HMC2 225M-6	30	980	58	7,1	91,7	91,7	86,5	0,81	290	2,0	2,1	0,574	329
HMC2 250M-6	37	980	69	7,1	92,2	92,2	88,1	0,84	360	2,1	2,2	0,876	392
HMC2 280S-6	45	980	81	7,2	92,7	92,6	90,2	0,86	440	2,0	2,1	1,46	530
HMC2 280M-6	55	980	99	7,5	93,1	93,1	92,4	0,86	535	2,0	2,1	1,73	593
HMC2 315S-6	75	985	136	6,7	93,7	93,6	92,3	0,85	725	2,0	2,1	4,32	950
HMC2 315M-6	90	985	164	6,7	94,0	94,1	92,6	0,84	870	2,0	2,1	5,02	1070
HMC2 315L1-6	110	985	198	6,7	94,3	94,3	92,9	0,85	1060	2,0	2,1	5,73	1180
HMC2 315L2-6	132	985	234	6,7	94,6	94,6	93,1	0,86	1280	2,0	2,1	6,43	1260
HMC2 355M1-6	160	990	280	6,7	94,8	94,8	93,5	0,87	1545	2,0	2,1	10,9	1650
HMC2 355M2-6	200	990	349	6,7	95,0	95,0	93,8	0,87	1935	2,0	2,0	13,0	1775
HMC2 355L-6	250	990	436	7,3	95,0	95,0	93,8	0,87	2410	2,0	2,0	16,2	1970
HMC2 400M1-6	315	990	545	7,0	95,2	95,2	94,6	0,88	3040	1,9	2,0	18,0	2220
HMC2 400M2-6	355	990	615	7,0	95,3	95,3	94,7	0,88	3420	1,9	2,0	19,5	2500
HMC2 400L-6	400	990	685	7,0	95,8	95,8	95,0	0,88	3860	1,9	2,0	21,8	2900

Data at 400V 50Hz

At 230V 50Hz the current is $\sqrt{3}$ x current at 400V and at 690V the current is current at 400V / $\sqrt{3}$. All other data are identical.

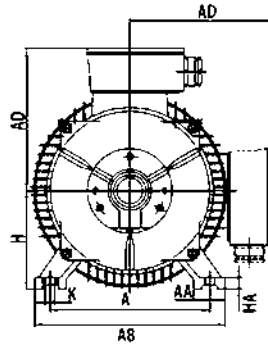
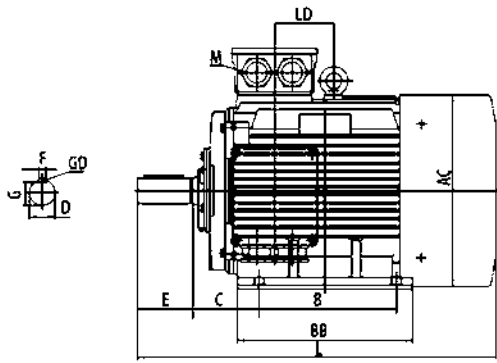

IE2 / B3

Motor type	Pole	A	AA	AB	AC	AD	B	BB	C	D	E	F	G	GD	H	HA	HD	K	L	LD
HMA2 80		125	27	160	158	128	100	122	48	19	40	6	15,5	6	80	12	208	10	290	-
HMA2 90S		140	35	175	175	132	100	155	56	24	50	8	20	7	90	13	222	10	335	-
HMA2 90L		140	35	175	175	132	125	155	56	24	50	8	20	7	90	13	222	10	361	-
HMA2 100		160	42	205	197	147	140	176	63	28	60	8	24	7	100	12	247	12	400	-
HMA2 112M1		190	45	222	220	169	140	180	70	28	60	8	24	7	112	13	281	12	394	-
HMA2 112M2		190	45	222	220	169	140	180	70	28	60	8	24	7	112	13	281	12	422	-
HMA2 132S		216	50	256	260	188	140	180	89	38	80	10	33	8	132	16,5	320	12	462	-
HMA2 132M1		216	50	256	260	188	178	218	89	38	80	10	33	8	132	16,5	320	12	500	-
HMA2 132M2		216	50	256	260	188	178	218	89	38	80	10	33	8	132	16,5	320	12	525	-
HMC2 160M	-	254	73	320	316	277	210	260	108	42	110	12	37	8	160	20	420	14,5	615	111
HMC2 160L	-	254	73	320	316	277	254	305	108	42	110	12	37	8	160	20	420	14,5	670	111
HMC2 180M	-	279	73	355	356	297	241	315	121	48	110	14	42,5	9	180	22	455	14,5	700	173
HMC2 180L	-	279	73	355	356	297	279	355	121	48	110	14	42,5	9	180	22	455	14,5	740	173
HMC2 200L	-	318	73	395	396	321	305	375	133	55	110	16	49	10	200	25	505	18,5	770	137
HMC2 225S	4,6,8	356	83	435	446	346	286	375	149	60	140	18	53	11	225	28	560	18,5	815	135
HMC2 225M	2	356	83	435	446	346	311	400	149	55	110	16	49	10	225	28	560	18,5	820	135
	4,6,8	356	83	435	446	346	311	400	149	60	140	18	53	11	225	28	560	18,5	845	135
HMC2 250M	2	406	88	490	490	367	349	445	168	60	140	18	53	11	250	30	615	24	915	154
	4,6,8	406	88	490	490	367	349	445	168	65	140	18	58	11	250	30	615	24	915	154
HMC2 280S	2	457	93	550	550	405	368	490	190	65	140	18	58	11	280	35	680	24	985	159
	4,6,8	457	93	550	550	405	368	490	190	75	140	20	67,5	12	280	35	680	24	985	159
HMC2 280M	2	457	93	550	550	405	419	540	190	65	140	18	58	11	280	35	680	24	1035	174
	4,6,8	457	93	550	550	405	419	540	190	75	140	20	67,5	12	280	35	680	24	1035	174
HMC2 315S	2	508	120	630	620	550	406	575	216	65	140	18	58	11	315	45	845	28	1215	205
	4,6,8	508	120	630	620	550	406	575	216	80	170	22	71	14	315	45	845	28	1245	205
HMC2 315M	2	508	120	630	620	550	457	685	216	65	140	18	58	11	315	45	845	28	1325	240
	4,6,8	508	120	630	620	550	457	685	216	80	170	22	71	14	315	45	845	28	1355	240
HMC2 315L	2	508	120	630	620	550	508	685	216	65	140	18	58	11	315	45	845	28	1325	240
	4,6,8	508	120	630	620	550	508	685	216	80	170	22	71	14	315	45	845	28	1355	240
HMC2 355M	2	610	120	730	700	671	560	760	254	75	140	20	67,5	12	355	52	1010	28	1515	312
	4,6,8	610	120	730	700	671	560	760	254	95	170	25	86	14	355	52	1010	28	1545	312
HMC2 355L	2	610	120	730	700	671	630	760	254	75	140	20	67,5	12	355	52	1010	28	1515	312
	4,6,8	610	120	730	700	671	630	760	254	95	170	25	86	14	355	52	1010	28	1545	312
HMC2 400M	4,6,8	686	120	806	856	690	630	1090	280	110	210	28	100	16	400	45	1010	35	1920	435
HMC2 400L	4,6,8	686	120	806	856	690	710	1090	280	110	210	28	100	16	400	45	1010	35	1920	435

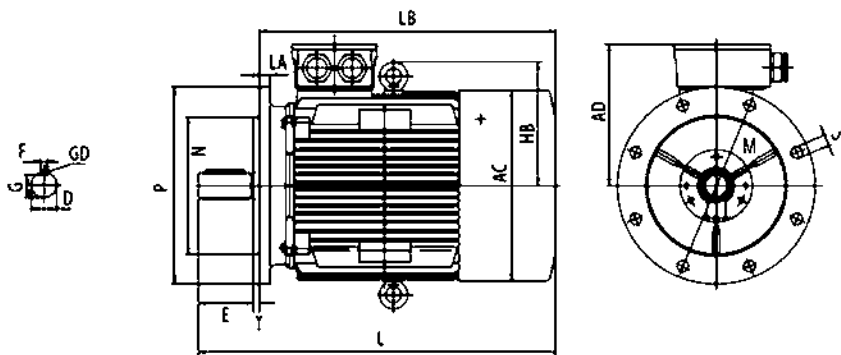

IE2 / B5

Motor type	Pole	AC	AD	D	E	F	G	GD	HB	L	LD	LA	LB	M	N	P	S	T
HMA2 63																		
HMA2 71																		
HMA2 80		158	128	19	40	6	15,5	6	-	290	-	10	250	165	130	200	4-Ø12	3,5
HMA2 90S		175	132	24	50	8	20	7	-	335	-	10	285	165	130	200	4-Ø12	3,5
HMA2 90L		175	132	24	50	8	20	7	-	361	-	10	311	165	130	200	4-Ø12	3,5
HMA2 100		197	147	28	60	8	24	7	-	400	-	14	340	215	180	250	4-Ø15	4
HMA2 112M1		220	169	28	60	8	24	7	146	394	-	14	334	215	180	250	4-Ø15	4
HMA2 112M2		220	169	28	60	8	24	7	146	422	-	14	362	215	180	250	4-Ø15	4
HMA2 132S		260	188	38	80	10	33	8	162	462	-	15	382	265	230	300	4-Ø15	4
HMA2 132M1		260	188	38	80	10	33	8	162	500	-	15	420	265	230	300	4-Ø15	4
HMA2 132M2		260	188	38	80	10	33	8	162	525	-	15	445	265	230	300	4-Ø15	4
HMC2 160M	-	316	277	42	110	12	37	8	222	615	256	15	505	300	250	350	4-Ø18,5	5
HMC2 160L	-	316	277	42	110	12	37	8	222	670	256	15	560	300	250	350	4-Ø18,5	5
HMC2 180M	-	356	297	48	110	14	42,5	9	237	700	271	15	590	300	250	350	4-Ø18,5	5
HMC2 180L	-	356	297	48	110	14	42,5	9	237	740	271	15	630	300	250	350	4-Ø18,5	5
HMC2 200L	-	396	321	55	110	16	49	10	262	770	313	17	660	350	300	400	4-Ø18,5	5
HMC2 225S	4,6,8	446	346	60	140	18	53	11	285	815	351	20	675	400	350	450	8-Ø18,5	5
HMC2 225M	2	446	346	55	110	16	49	10	285	820	321	20	710	400	350	450	8-Ø18,5	5
	4,6,8	446	346	60	140	18	53	11	285	845	351	20	705	400	350	450	8-Ø18,5	5
HMC2 250M	2	490	367	60	140	18	53	11	316	915	367	22	775	500	450	550	8-Ø18,5	5
	4,6,8	490	367	65	140	18	58	11	316	915	367	22	775	500	450	550	8-Ø18,5	5
HMC2 280S	2	550	405	65	140	18	58	11	345	985	356	22	845	500	450	550	8-Ø18,5	5
	4,6,8	550	405	75	140	20	67,5	12	345	985	356	22	845	500	450	550	8-Ø18,5	5
HMC2 280M	2	550	405	65	140	18	58	11	345	1035	356	22	895	500	450	550	8-Ø18,5	5
	4,6,8	550	405	75	140	20	67,5	12	345	1035	356	22	895	500	450	550	8-Ø18,5	5
HMC2 315S	2	620	550	65	140	18	58	11	430	1215	397	22	1075	600	550	660	8-Ø24	6
	4,6,8	620	550	80	170	22	71	14	430	1245	427	22	1075	600	550	660	8-Ø24	6
HMC2 315M	2	620	550	65	140	18	58	11	430	1325	397	22	1185	600	550	660	8-Ø24	6
	4,6,8	620	550	80	170	22	71	14	430	1355	427	22	1185	600	550	660	8-Ø24	6
HMC2 315L	2	620	550	65	140	18	58	11	430	1325	397	22	1185	600	550	660	8-Ø24	6
	4,6,8	620	550	80	170	22	71	14	430	1355	427	22	1185	600	550	660	8-Ø24	6
HMC2 355M	2	700	671	75	140	20	67,5	12	490	1515	424	25	1375	740	680	800	8-Ø24	6
	4,6,8	700	671	95	170	25	86	14	490	1545	454	25	1375	740	680	800	8-Ø24	6
HMC2 355L	2	700	671	75	140	20	67,5	12	490	1515	424	25	1375	740	680	800	8-Ø24	6
	4,6,8	700	671	95	170	25	86	14	490	1545	454	25	1375	740	680	800	8-Ø24	6
HMC2 400M	4,6,8	856	690	110	210	28	100	16	600	1920	435	25	1710	940	880	1000	8-Ø28	6
HMC2 400L	4,6,8	856	690	110	210	28	100	16	600	1920	435	25	1710	940	880	1000	8-Ø28	6

Motor type	B14A small or C DIN flange													B14B big				
	AC	D	E	F	G	GD	L	LB	M	N	P	S	T	M	N	P	S	T
HMA2 80	158	19	40	6	15,5	6	290	250	100	80	120	4-M6	3	130	110	160	4-M8	3,5
HMA2 90S	175	24	50	8	20	7	335	285	115	95	140	4-M8	3	130	110	160	4-M8	3,5
HMA2 90L	175	24	50	8	20	7	361	311	115	95	140	4-M8	3	130	110	160	4-M8	3,5
HMA2 100	197	28	60	8	24	7	400	340	130	110	160	4-M8	3,5	165	130	200	4-M10	4
HMA2 112M1	220	28	60	8	24	7	394	334	130	110	160	4-M8	3,5	165	130	200	4-M10	4
HMA2 112M2	220	28	60	8	24	7	422	362	130	110	160	4-M8	3,5	165	130	200	4-M10	4
HMA2 132S	260	38	80	10	33	8	462	382	165	130	200	4-M10	4					
HMA2 132M1	260	38	80	10	33	8	500	420	165	130	200	4-M10	4					
HMA2 132M2	260	38	80	10	33	8	525	445	165	130	200	4-M10	4					

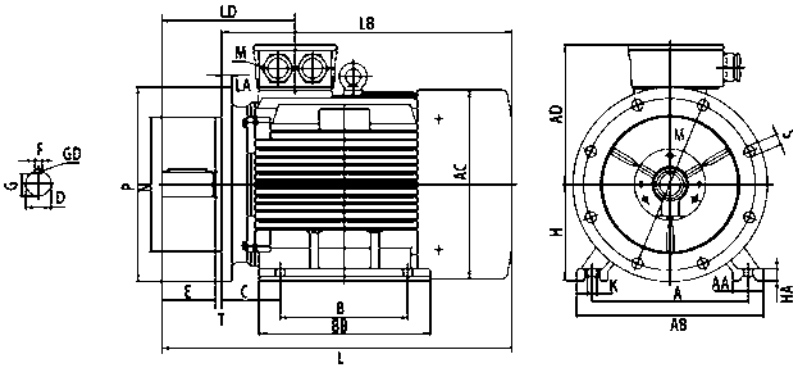

IE2 / B35

Motor type	Pole	A	AA	AB	AC	AD	B	BB	C	D	E	F	G	GD	H	HA	K	L	LD	LA	LB	M	N	P	S	T
HMA2 80	-	125	27	160	158	128	100	122	48	19	40	6	15,5	6	80	12	10	290	-	10	250	165	130	200	4-Ø12	3,5
HMA2 90S	-	140	35	175	175	132	100	155	56	24	50	8	20	7	90	13	10	335	-	10	285	165	130	200	4-Ø12	3,5
HMA2 90L	-	140	35	175	175	132	125	155	56	24	50	8	20	7	90	13	10	361	-	10	311	165	130	200	4-Ø12	3,5
HMA2 100	-	160	42	205	197	147	140	176	63	28	60	8	24	7	100	12	12	400	-	14	340	215	180	250	4-Ø15	4
HMA2 112M1	-	190	45	222	220	169	140	180	70	28	60	8	24	7	112	13	12	394	-	14	334	215	180	250	4-Ø15	4
HMA2 112M2	-	190	45	222	220	169	140	180	70	28	60	8	24	7	112	13	12	422	-	14	362	215	180	250	4-Ø15	4
HMA2 132S	-	216	50	256	260	188	140	180	89	38	80	10	33	8	132	16,5	12	462	-	15	382	265	230	300	4-Ø15	4
HMA2 132M1	-	216	50	256	260	188	178	218	89	38	80	10	33	8	132	16,5	12	500	-	15	420	265	230	300	4-Ø15	4
HMA2 132M2	-	216	50	256	260	188	178	218	89	38	80	10	33	8	132	16,5	12	525	-	15	445	265	230	300	4-Ø15	4
HMC2 160M	-	254	65	320	316	277	210	260	108	42	110	12	37	8	160	20	14,5	615	256	15	505	300	250	350	4-Ø18,5	5
HMC2 160L	-	254	65	320	316	277	254	305	108	42	110	12	37	8	160	20	14,5	670	256	15	560	300	250	350	4-Ø18,5	5
HMC2 180M	-	279	70	355	356	297	241	315	121	48	110	14	42,5	9	180	22	14,5	700	271	15	590	300	250	350	4-Ø18,5	5
HMC2 180L	-	279	70	355	356	297	279	355	121	48	110	14	42,5	9	180	22	14,5	740	271	15	630	300	250	350	4-Ø18,5	5
HMC2 200L	-	318	70	395	396	321	305	375	133	55	110	16	49	10	200	25	18,5	770	313	17	660	350	300	400	4-Ø18,5	5
HMC2 225S	4,6,8	356	75	435	446	346	286	375	149	60	140	18	53	11	225	28	18,5	815	351	20	675	400	350	450	8-Ø18,5	5
HMC2 225M	2	356	75	435	446	346	311	400	149	55	110	16	49	10	225	28	18,5	820	321	20	710	400	350	450	8-Ø18,5	5
	4,6,8	356	75	435	446	346	311	400	149	60	140	18	53	11	225	28	18,5	845	351	20	705	400	350	450	8-Ø18,5	5
HMC2 250M	2	406	80	490	490	367	349	445	168	60	140	18	53	11	250	30	24	915	367	22	775	500	450	550	8-Ø18,5	5
	4,6,8	406	80	490	490	367	349	445	168	65	140	18	58	11	250	30	24	915	367	22	775	500	450	550	8-Ø18,5	5
HMC2 280S	2	457	85	550	550	405	368	490	190	65	140	18	58	11	280	35	24	985	356	22	845	500	450	550	8-Ø18,5	5
	4,6,8	457	85	550	550	405	368	490	190	75	140	20	67,5	12	280	35	24	985	356	22	845	500	450	550	8-Ø18,5	5
HMC2 280M	2	457	85	550	550	405	419	540	190	65	140	18	58	11	280	35	24	1035	356	22	895	500	450	550	8-Ø18,5	5
	4,6,8	457	85	550	550	405	419	540	190	75	140	20	67,5	12	280	35	24	1035	356	22	895	500	450	550	8-Ø18,5	5
HMC2 315S	2	508	120	635	620	550	406	575	216	65	140	18	58	11	315	45	28	1215	397	22	1075	600	550	660	8-Ø24	6
	4,6,8	508	120	635	620	550	406	575	216	80	170	22	71	14	315	45	28	1245	427	22	1075	600	550	660	8-Ø24	6
HMC2 315M	2	508	120	635	620	550	457	685	216	65	140	18	58	11	315	45	28	1325	397	22	1185	600	550	660	8-Ø24	6
	4,6,8	508	120	635	620	550	457	685	216	80	170	22	71	14	315	45	28	1355	427	22	1185	600	550	660	8-Ø24	6
HMC2 315L	2	508	120	635	620	550	508	685	216	65	140	18	58	11	315	45	28	1325	397	22	1185	600	550	660	8-Ø24	6
	4,6,8	508	120	635	620	550	508	685	216	80	170	22	71	14	315	45	28	1355	427	22	1185	600	550	660	8-Ø24	6
HMC2 355M	2	610	116	730	700	671	560	760	254	75	140	20	67,5	12	355	52	28	1515	424	25	1375	740	680	800	8-Ø24	6
	4,6,8	610	116	730	700	671	560	760	254	95	170	25	86	14	355	52	28	1545	454	25	1375	740	680	800	8-Ø24	6
HMC2 355L	2	610	116	730	700	671	630	760	254	75	140	20	67,5	12	355	52	28	1515	424	25	1375	740	680	800	8-Ø24	6
	4,6,8	610	116	730	700	671	630	760	254	95	170	25	86	14	355	52	28	1545	454	25	1375	740	680	800	8-Ø24	6
HMC2 400M	4,6,8	686	120	806	856	690	630	1090	280	110	210	28	100	16	400	45	35	1920	435	25	1710	940	880	1000	8-Ø28	6
HMC2 400L	4,6,8	686	120	806	856	690	710	1090	280	110	210	28	100	16	400	45	35	1920	435	25	1710	940	880	1000	8-Ø28	6

Bearings

Motor type	Drive end		None drive end	
	2 pole	4,6,8 pole	2 pole	4,6,8 pole
HMA2 80	6204-ZZ/C3		6204-ZZ/C3	
HMA2 90	6205-ZZ/C3		6204-ZZ/C3	
HMA2 100	6206-ZZ/C3		6206-ZZ/C3	
HMA2 112	6306-ZZ/C3		6306-ZZ/ C3	
HMA2 132	6308-ZZ/C3		6308-ZZ/C3	
HMC2 160	6309-ZZ/C3	6309-ZZ/C3	6309-ZZ/C3	
HMC2 180	6311-ZZ/C3	6311-ZZ/C3	6311-ZZ/C3	
HMC2 200	6312-ZZ/C3	6312-ZZ/C3	6312-ZZ/C3	
HMC2 225	6312-ZZ/C3	6313-ZZ/C3	6312-ZZ/C3	
HMC2 250	6313/C3	6314/C3	6313/C3	
HMC2 280	6314/C3	6317/C3	6314/C3	
HMC2 315	6317/C3	NU319/C3 (B3) 6319/C3 (B5/B35)	6317/C3	6319/C3
HMC2 355	6319/C3	NU322/C3 (B3) 6322/C3 (B5/B35)	6319/C3	6322/C3
HMC2 400	6322/C3	6326/C3	6322/C3	6326/C3

Cable Gland

Motor type	Cable Glands	Blind caps
HMA2 80	1 x M20x1,5	1 x M20x1,5
HMA2 90	1 x M20x1,5	1 x M20x1,5
HMA2 100	1 x M20x1,5	1 x M20x1,5
HMA2 112	1 x M20x1,5	1 x M20x1,5
HMA2 132	2 x M25x1,5	1 x M20x1,5
HMC2 160	2 x M40x1,5	2 x M20x1,5
HMC2 180	2 x M40x1,5	2 x M20x1,5
HMC2 200	2 x M50x1,5	2 x M20x1,5
HMC2 225	2 x M50x1,5	2 x M20x1,5
HMC2 250	2 x M63x1,5	2 x M20x1,5
HMC2 280	2 x M63x1,5	2 x M20x1,5
HMC2 315	2 x M63x1,5	2 x M20x1,5
HMC2 355	2 x M72x2,0	2 x M20x1,5
HMC2 400	2 x M80x2,0	2 x M20x1,5

Rating plate

IE2		HOYER		CE	
www.hoyermotors.com					
Type: HMC2 280M-4		Serial No: SH984762-123			3~Motor
D.E. 6317	N.D.E 6314	40°C	668Kg	IP55	Ins.cl. F
V. Δ / Y	Hz	KW	rpm	A. Δ / Y	Cos φ
400/690	50	90	1485	156/90	0.88
480/830	60	108	1780	156/90	0.88
IE2 eff. at: 400/690V 50Hz 1/1: 94.2% 3/4: 94.5% 1/2: 92.7%					
IM: B3	Year: 2011				IEC 60034-1

Mounting positions

B6

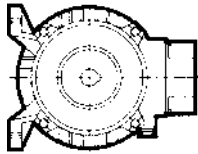

B3

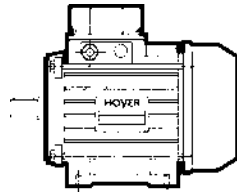

B5

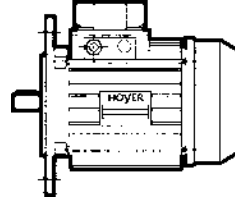

B14

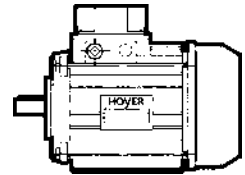

B7

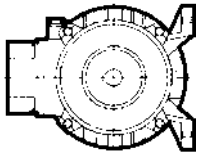

V5

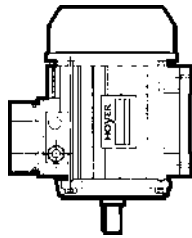

V1

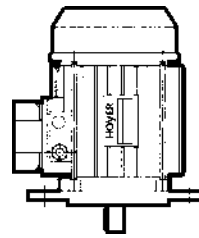

V18

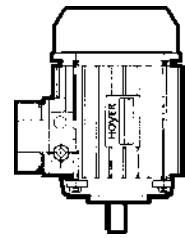

B8

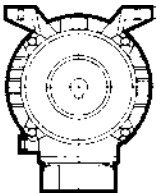

V6

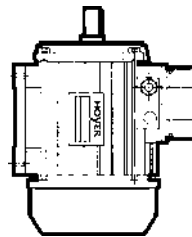

V3

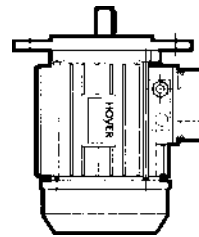

V19

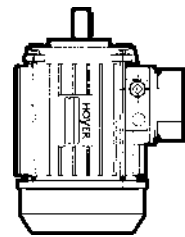

B3/B5

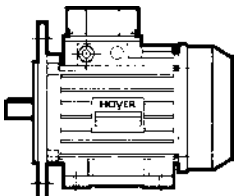

B3/B14

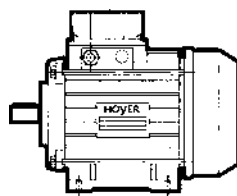

V1/V5

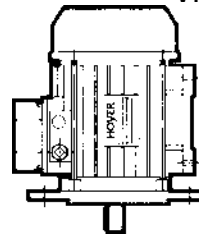

V3/V6

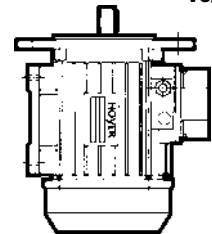

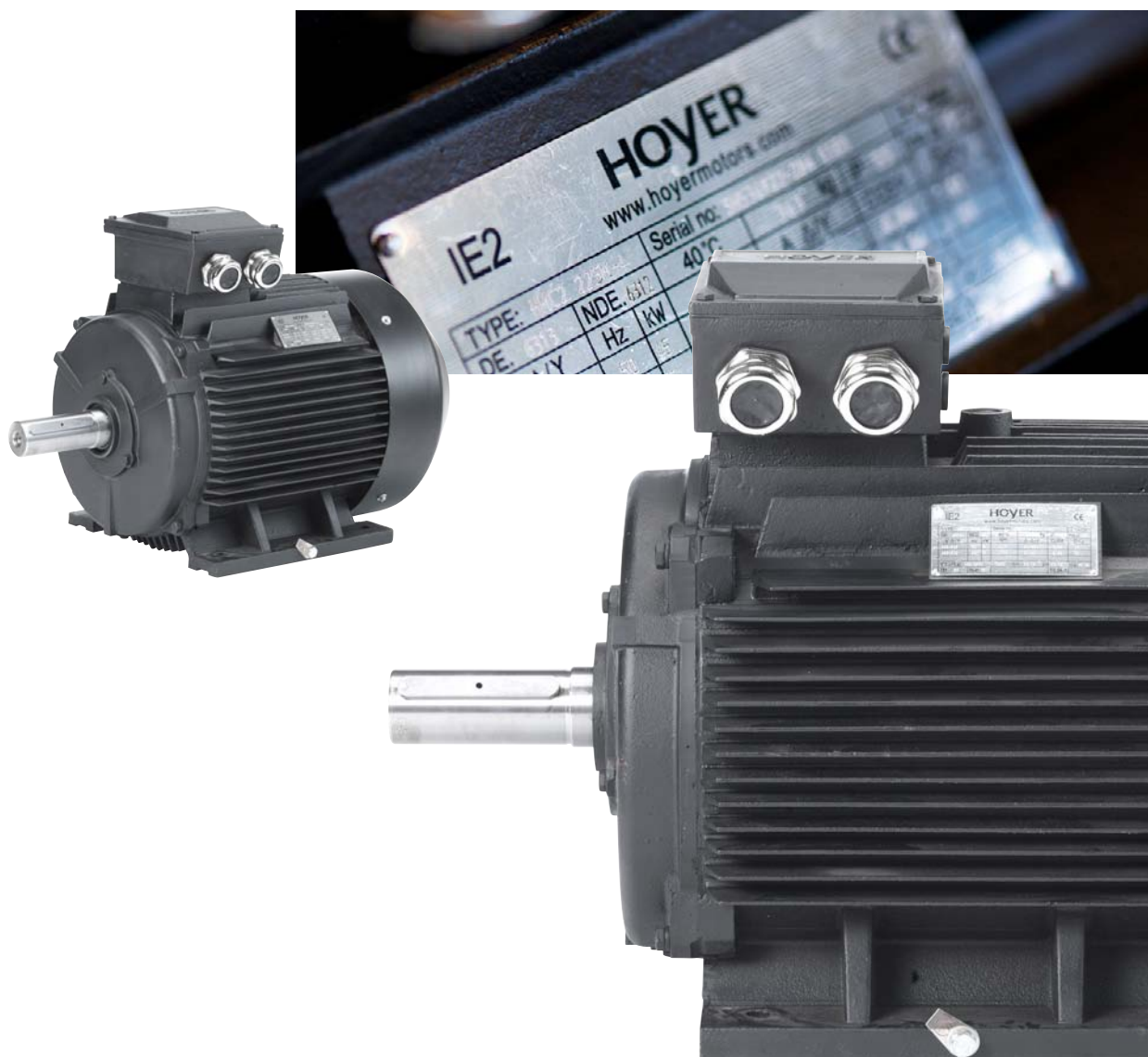

HOYER

EXCEEDING EXPECTATIONS

Hoyer Motors, IE2 Motors, June 2011

Headquarter

Svend Hoyer A/S . Over Hadstenevej 42 . DK-8370 Hadsten
T (+45) 86 98 21 11 . F (+45) 86 98 17 79 . svendhoyer@svendhoyer.com

Sales Office China

Hoyer Motors Asia . 177, Jinchuan Road . NIP, Zhenhai . Ningbo 315221 . China
T (+86) 574 2628 1577 . F (+86) 574 2628 1569 . hoyermotors@hoyermotors.com

www.hoyermotors.com